

Ohmview 2000 Setup for Temperature Compensation

On the Aux Input tab

Communication Statistics: 100%

Select Tabs: Select Temperature Compensation

Process Info: Setup

Calibration: Gauge Info, Diagnostics, Alarms

Linearizer Type: Table - Non linear

Status

Aux Channel Filter Value: 0 seconds

Process Compensation Select:

- None
- Temperature Compensation
- Mass Flow
- Summation

Aux Channel Status: ON

Disconnect

On the PV Units tab

Communication Statistics: 100%

Select Tabs: Select degAPI

Process Info: Setup

Calibration: Gauge Info, Diagnostics, Alarms

Linearizer Type: Table - Non linear

Status

Density Units:

- SPG
- g/cm3
- kg/m3
- degAPI
- lb/ft3
- g/ml
- dBeum L
- dBeum H
- deg Twed
- %
- lb/gal
- kg/l
- g/l
- lb/m3
- cm3yd3
- % solid
- % solution
- special

Carrier SPG: 0.000

Product SPG: 0.000

Disconnect

On the Temperature Comp tab

Communication Statistics: 100%

Select Tabs: Select the Temperature Units

Process Info: Setup

Calibration: Gauge Info, Diagnostics, Alarms

Linearizer Type: Table - Non linear

Status

Reference Temp: 0.00

Temperature Offset: 0.00

Process Temperature: 20.00

Temperature Units:

- deg C
- deg F

Device Temp Coeffs:

- coeff 0: 0.000000
- coeff 1: 0.000000E+0
- coeff 2: 0.000000E+0

Process Temp Coeffs:

- coeff 0: 0.000000
- coeff 1: 0.000000E+0
- coeff 2: 0.000000E+0
- coeff 3: 0.000000E+0

Disconnect

Analog Input Board Cal

The Analog in Cal feature has the following menu components:

- Analog Input Low Counts—Average counts from analog input low density calibration
- Analog Input Low Cal—Use this function to calibrate the Analog Input board for the low input signal of the auxiliary span
- Analog Input High Counts—Average counts from analog input high density calibration
- Analog Input High Cal—Use this function to calibrate the Analog Input board for the high input signal of the auxiliary span

For further information concerning the Analog in Cal feature, contact VEGA Americas, Inc.

Working with a linear temperature device

If you have a temperature device that is not an RTD, but provides a linear voltage output as a function of temperature, you can use the temperature compensation feature by performing the setups that follow.

To set up temperature compensation with a linear device

1. Calculate the value of the device temperature coefficient 1 by using the following equation:

$$\text{Coeff 1} = (\text{Temperature span}) / (\text{Analog Input High Calibration value} - \text{Analog Input Low Calibration value})$$
2. Calculate the value of the device temperature coefficient 0 by using the following equation:

$$0 = (\text{Max Temperature}) - (\text{coefficient 1} \times \text{Analog Input High Calibration value})$$
3. Set the device temperature coefficient 3 to 0.

For example, suppose you have a 0 to 10V temperature measurement device with a temperature span of 20 to 200 °C. The configuration of the analog input circuit board is for an input range of 0 to 10V.

- Set the analog input signal to 10V and perform an Analog Input High Calibration to find out the highest output frequency of the Analog Input Circuit Board. For this example, assume this value is set at 29,760 Hz.
- Set the analog input signal to zero volts and perform an Analog Input Low Calibration. For this example, assume 100 Hz.

$$\text{Device Coefficient 1} = (200 - 20) / (29760 - 100) = 0.006069$$

$$\text{Device Coefficient 0} = 200 - (0.006069 \times 29760) = 19.39$$

VEGA Customer Service information

To request field service within the United States and Canada, call 513-272-0131.

Customers outside of the United States and Canada should contact their local VEGA representative for parts and service.

Copyright 2011 VEGA Americas, Inc., Cincinnati, Ohio. All rights reserved. This document contains proprietary information of VEGA Americas, Inc. It shall not be reproduced in whole or in part, in any form, without the expressed written permission of VEGA Americas, Inc. The material in this document is provided for informational purposes and is subject to change without notice.

VEGA

DSGH TEMPERATURE COMPENSATION FOR °API QUICK REFERENCE GUIDE

Version 1.0



SAFETY INSTRUCTIONS

Refer to the Radiation Safety Manual and Reference CD that came with your source holder.

Always refer to the safety instructions in this guide and the country specific installation standards. Follow the prevailing safety regulations and accident prevention rules of your company and country.

General

Ambient temperature should be between -20 °C ... +60 °C (-4 °F ... +140 °F). There is an option available for lower temperatures.

Safety information for EX areas

This equipment is suitable for use in the following environment:

- CSA Class I, Div 1, Groups A, B, C, & D
- CSA Class I, Div 2, Groups A, B, C, & D
- CSA Class II, Div 1 Groups E, F, & G
- CSA Class II, Div 2, Groups E, F & G
- ATEX Certificate PTB01 ATEX 1125 II 2 G D EExd IIC T6 Ta = -20 °C to +60°C or II 2G EExd IIB+H2 T6 Ta = -50 °C to +60°C
- NEMA Type 4X IP66
- Non-hazardous locations

Special installation, maintenance, or operating instructions

If it is necessary to open the sensor, the following warning applies:

EXPLOSION HAZARD - Do not disconnect equipment unless power has been switched off or the area is known to be non-hazardous.

AVERTISSEMENT: - RISQUE D'EXPLOSION - AVANT DE DÉCONNECTER L'ÉQUIPEMENT, COUPER LE COURANT OU S'ASSURER QUE L'EMPLACEMENT EST DÉSIGNÉ NON DANGEREUX.

Caution! Open circuits before removing cover. An explosion-proof seal shall be installed within 450 mm (18") of the enclosure.

AVERTISSEMENT: - Ouvrir les circuits avant d'enlever le couvercle. Un scellement doit être installé à moins de 450 mm du boîtier.

Caution! - Allow a minimum of 10 minutes before opening the GEN2000® for internal inspection. This allows time for the gauge to de-energize, cool, and full capacitor discharge.

Note: Not all DCS hosts support the use of menus. If your DCS system does not support menus, you must use the list of methods to find the function. To see the list of parameters for each transducer block, click on the gauge in the left pane, right-click, select Configure, and select the appropriate transducer block.

Enter Device Temp Coefficients if necessary

Enter Temperature Offset if necessary

Enter Process Temp Coefficients if necessary

PROCESS TEMPERATURE—COMPENSATED DENSITY

Temperature changes can cause process materials to expand and change density. Using the Temperature Compensation feature normalizes the process density to the reference temperature density. You will need a temperature probe and a DSGH with an analog input board to adjust the density indication. The temperature probe measures the process temperature, sends an analog signal to the DSGH, which adds the density correction, and then the DSGH sends a 4 ... 20 mA calibrated, temperature corrected signal.

Installation requirements

Use of an RTD temperature probe requires an VEGA analog input circuit board (p/n 243409). The analog input circuit board mounts to the top of the unit with a mounting bracket. (p/n 243563). The analog input kit's part number is 243585.

Interconnect for RTD temperature probe

Use the J1 4-pin connector to wire the analog circuit board to the RTD.

Analog circuit board to RTD pin and connections

J1 pin	RTD connection
1	-Signal
2	+Signal
3	+RTD
4	-RTD

The analog input circuit board interfaces with the power supply board through the 14-pin connector.

Analog circuit board to GEN2000 power supply board pin and connections

P1 pin	Analog Input Board
8	+6V
9	GND
11	Freq +
12	Freq -

We recommend using shielded 18AWG or 20 AWG cable for the input signal. The maximum length for an externally generated voltage signal depends on the signal loss in the cable. To compensate for signal loss associated with wire length, use a 4-wire connection.

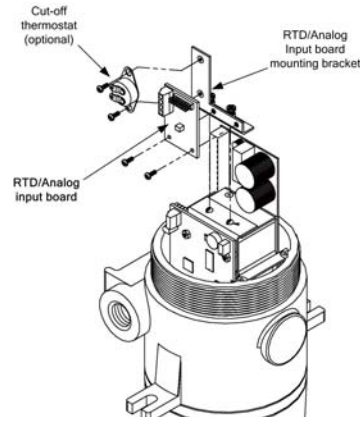
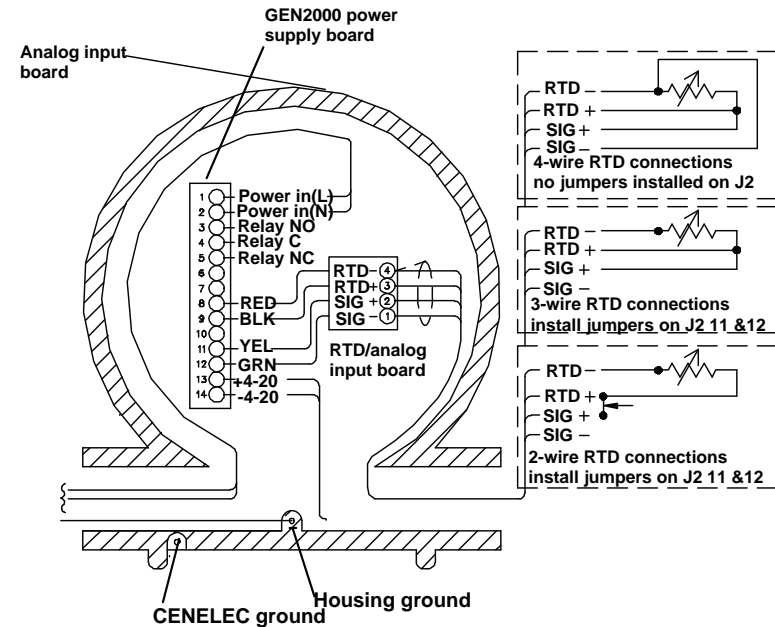

DSGH wiring and jumper connections

J2 Jumper block configuration

RTD/Analog Use	—	All jumpers open
0 ... 5 mA	1 and 2	11 and 12
0 ... 10 mA	3 and 4	11 and 12
0 ... mA	5 and 6	11 and 12
0 ... 50 mA	7 and 8	11 and 12
0 ... 100 mA	9 and 10	11 and 12
0 ... 1 V	—	11 and 12
0 ... 10 V	13 and 14	11 and 12
0 ... 25 V	15 and 16	11 and 12

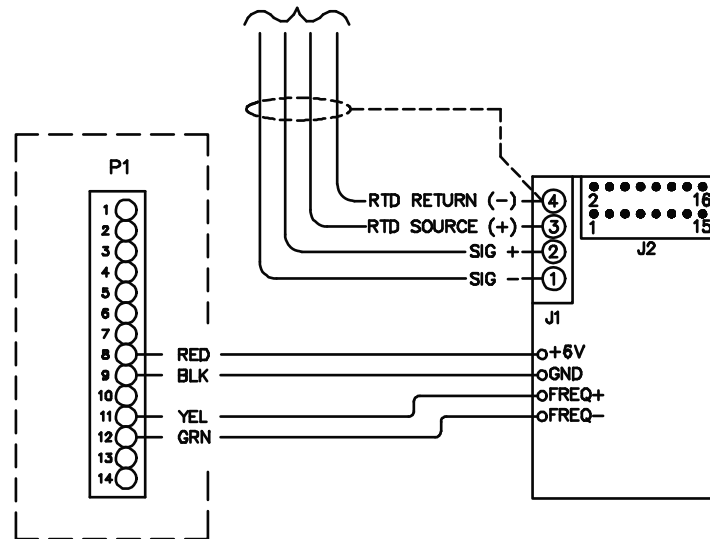

Temperature compensation parameters

Parameter	Description
Temperature Units	Display units for the temperature (°C or °F)
Reference Temperature	The reference temperature is the temperature to which the density reading adjusts..
Temperature Offset	Corrects for any error between the indicated (displayed) and actual process temperature. Note: the correction is always applied in °C. View the Temperature Comp. tab to determine if you need to adjust the Temperature Probe Offset. If the temperature is not correct, adjust the Temperature Coefficient Offset value to get the correct reading. Formula: With °C Offset = Actual – Display With °F Offset = Actual – Display/1.8
Process Temperature	Current temperature of the process material in °C or °F

Parameter	Description
Device Temperature Coefficients	Use the device temperature coefficient to calibrate the temperature measuring device for a linear measurement of the process temperature. The default values are for a PT100 RTD. Contact VEGA if you are using a different device.

Coeff	Temperature Units °C	Temperature Units °F
1	-243.50029	-135.2779
2	0.01909	0.010606
3	7.90E-8	4.38E-8

If the temperature units change, the coefficients convert automatically.

Polynomial coefficients to linearize the process; dependent on the process material and how it changes with temperature. Your process-testing lab should determine these coefficients. Enter the coefficients in SPG/ °C or SpG/ °F. For a linear correction, the coefficients 0, 2, and 3 must be set to zero. The process temperature is measured using a PT100 platinum RTD. If using another linear device, refer to "Working with a linear temperature device."

The algorithm for a linear correction for process temperature is:

$$d_c = d_m + [\text{coeff}_1 (t_{\text{ref}} - t)]$$

Where:

d_c = corrected density reading

d_m = measured density reading

t_{ref} = reference temperature (15.5 °C/60 °F)

t = actual process temperature

coeff 1 = process temperature coefficient

Process Temperature Coefficients

°API	Coeff 1 (°C)	Coeff 1 (°F)
0–14.9	.00063/ °C	.00035/ °F
15–34.9	.00072/ °C	.00040/ °F
35–50.9	.00091/ °C	.00050/ °F
25–75	.00087/ °C	.000487/ °F

Determining process coefficient P₁:

$$P_1 = \frac{d_L - d_H}{t_L - t_H}$$

Where:

d_L = density at low temperature

d_H = density at high temperature

t_L = low process temperature

t_H = high process temperature

Platinum 100 RTD temperature to frequency

The table below gives the conversion of temperature in °C to the frequency output of the Platinum 100 RTD.

Platinum 100 RTD temperature to frequency output					
Temp (degC)	Frequency	Temp (degC)	Frequency	Temp (degC)	Frequency
-100	7313.11	110	17268.20	310	26166.26
-90	7803.40	120	17726.94	320	26595.87
-80	8292.48	130	18183.25	330	27024.27
-70	8777.91	140	18638.35	340	27452.67
-60	9263.35	150	19093.45	350	27878.64
-50	9746.36	160	19544.90	360	28302.18
-40	10226.94	170	19996.36	370	28725.73
-30	10706.31	180	20446.60	380	29148.06
-20	11184.47	190	20894.42	390	29567.96
-10	11661.41	200	21342.23	400	29986.65
0	12135.92	210	21787.62		
10	12609.22	220	22229.37		
20	13081.31	230	22674.76		
30	13552.18	240	23115.29		
40	14021.84	250	23555.83		
50	14490.29	260	23993.93		
60	14968.45	270	24430.83		
70	15422.33	280	24866.50		
80	15885.92	290	25300.97		
90	16348.30	300	25734.22		
100	16809.47				